

CHAPTER 3 TRANSPORTATION

3.1 GENERAL CONSIDERATIONS

The overall goal of this chapter is to encourage the uniform development of an integrated, fully accessible public transportation system that will facilitate present and future travel demand with minimal environmental impact to the community as a whole.

This chapter provides minimum infrastructure development standards.

- A. For traffic impact studies (TIS), see the Sedro-Woolley Traffic Impact Study Guidelines.
- B. Classification of streets by RCW 35.78.010

Major arterials, which are defined as transportation arteries which connect the focal points of traffic interest within a city; arteries which provide communications with other communities and the outlying areas; or arteries which have relatively high traffic volume compared with other streets within the city;

Minor Arterials, which are defined as routes which serve lesser points of traffic interest within a city; provide communication with outlying districts in the same degree or serve to collect and distribute traffic from the major arterials to the local streets;

[Local] Access streets, which are defined as land service streets and are generally limited to providing access to abutting property. They are tributary to the major and secondary thoroughfares and generally discourage through traffic.

- C. Collectors, although not defined by RCW 35.78.010, are defined as streets which collect and distribute traffic from Principal Arterials, Secondary Arterials, and Collector Arterials to the local streets.

3.2 STREETS

3.2.1 General

Street design must provide for the maximum loading conditions anticipated. The width and grade of the pavement must conform to specific standards set forth herein for safety and uniformity.

3.2.2 Design Standards

The design of streets and roads will depend upon their type and usage. The design elements of City streets will conform to City standards as set forth herein, (See Minimum Street Design Standards, Table 1, in the Appendix.) and the current edition of Sedro-Woolley Road Standards (SWRS) **once it is developed**. Where there are conflicts, the SWMC shall supercede the SWRS, unless directed otherwise by the Public Works Director / City Engineer. Please bring conflicts to the attention of the Public Works Director / City Engineer. Standard design street sections are shown on details in the Appendix.

The layout of streets will provide for the connectivity of existing streets in adjoining subdivisions or of their proper projection when adjoining property is not subdivided. (See Minimum Street Design Standards, Table 1, in the Appendix.)

- A. Alignment. Alignment of Principal Arterials, Secondary Arterials and Collector Arterials will conform as nearly as possible with that shown in the Comprehensive Plan and any sub-area plans.
- B. Grade. Street grade should conform closely to the natural contour of the land. In some cases the Public Works Director / City Engineer may require a different grade. The minimum allowable grade will be 0.5 percent. The maximum allowable grade will be as listed in Table 1 of the Appendix, depending upon the street classification, or 10% max for any classification.
- C. Cross Slope. The standard cross slope is two percent (2%) for bituminous roadways. Modifications to roadways with non-standard cross slopes shall include bringing the roadway cross section into compliance with the current standards.

Table 1. Roadway Design Minimum Standards

	Notes	Principal Arterial	Secondary Arterial	Collector Arterial	Minor Collector	Local Access
Design Speed (mph)	All	45*	45*	45*	35*	25
Maximum Grade (%)	Flat	6	6	6	6	6
	Rolling	7	8	8	8	8
	Mountainous	8	10	10	10**	10**
Sidewalk Width (ft.)	CBD	11.5	11.5	11.5	11.5	11.5
	Other	8 ⁺	8 ⁺	8/5*** ⁺	8/5*** ⁺	5 ⁺
Landscape Strip Width (ft.)	CBD	5 x 5 pit every 50'	5 x 5 pit every 50'	5 x 5 pit every 50'	5 x 5 pit every 50'	5 x 5 pit every 50'
	Other	10/5 ⁺⁺	10/5 ⁺⁺	10/5 ⁺⁺	10/5 ⁺⁺	10/5 ⁺⁺
Curb/Ditch	All	Curb ⁺⁺⁺	Curb ⁺⁺⁺	Curb ⁺⁺⁺	Curb ⁺⁺⁺	Curb ⁺⁺⁺
Filter Strip (ft.)	(As Applicable)	10	10	10	10	10
Bike Lane (ft.)	(As Applicable, See Map)	6 ⁺	6 ⁺	6 ⁺	5 ⁺	5 ⁺
Lane Width (ft.)	All	12	12	11	11	11
Two-Way Lt. Turn Lane Width (ft.)		13	13	13	N/A	N/A
Parking Lane Width (ft.)	CBD	N/A	N/A	8/15 [#]	8/15 [#]	8/15 [#]
	(As Applicable)	N/A	N/A	8	8	8
Min. Right-of-Way Width (ft.)	CBD	100	80	80	80	--
	Other ^{###}	100	100/80	80/66	80/66	60
Cross-section(s)	See Appendix					

- * = Max. Posted Speed + 10 mph, except school zones.
- ** = Grades of up to 12% may be allowed by modification, and approval from the Fire Chief (IFC D103.2).
- *** = 5' if sidewalk is not placed immediately adjacent to curb (landscape strip)
- + = 11' if combined sidewalk / bike path separated from roadway
- ++ = 10' unless outside 8' sidewalk, then 5' min.
- +++ = Unless alternative design, such as filter strip w/ swale
- # = 15' (13' painted width in CBD) if 55-degree diagonal parking (allowed in CBD)
- ### = Minimum based on 0.5' behind back of walk. Phase 1 Arterial requires 80'. Phase 2 Collector Arterial = Phase 1 Secondary Arterial. (42' curb-to-curb)

D. Width. The pavement and right-of-way width depend upon the street classification. The minimum widths allowed are shown in the Appendix.

Street widths will be measured from face of curb to face of curb on streets with Portland Cement Concrete curb, and edge of pavement to edge of pavement in ditch section streets.

E. The General Notes in the Appendix will be included on any plans dealing with street design in addition to all applicable requirements.

Provisions for Utility Service:

F. Existing Utilities - It is the responsibility of the developer to verify the location

of all existing and proposed underground and aerial utilities prior to design. The developer shall coordinate the design and installation with the respective utility companies.

- G. Utility Service - All properties adjacent to a new street shall be provided with water, sewer (sanitary sewer), storm drainage, electricity, telephone, cable TV, and natural gas, if available, in such a manner as to avoid future street excavation and the associated disruptions to traffic. The number and location of service “stub outs” to be installed shall be based upon the lot configuration of the properties adjacent to the proposed street improvements. Utilities shall be provided underground.

3.2.3 Naming and Numbering

Streets and roads will be named according to specific criteria. “Street” and/or “Avenue” indicates that the roadway is within the City limits, and “Road” indicates that the roadway is within or partially outside of the City limits. “Lane” or “Court” indicates short, private driveways or roadways. “Place” indicates a public cul-de-sac. “Boulevard” indicates SR-20 or a roadway with a “boulevard” road section. “Circle” or “Loop” indicates a roadway which travels in more than two cardinal directions, (N-S-E-W) and does or tends to connect to the same roadway at either end. “Way” indicates a roadway which is not in alignment with or travels contrary to the cardinal directions. (N-S-E-W) “Drive” indicates a publicly owned non-standard street.

The City of Sedro-Woolley is divided into four sections by the BNSF Railroad Right-of-Way and SR-20:

North of SR-20: “Avenues” run east-west. “Streets” run north-south. Street signs should indicate “North” or “N” preceding the street name and a suffix according to the standard. See signing below.

South of SR-20 : “Avenues” run east-west. “Streets” run north-south. Street signs should indicate “South” or “S” preceding the street name and a suffix according to the standard. See signing below.

West of BNSF Railroad: “Avenues” run east-west. “Streets” run north-south. Street signs should indicate “West” or “W” preceding the street name and a suffix according to the standard. See signing below.

East of BNSF Railroad: “Avenues” run east-west. “Streets” run north-south. Street signs should indicate “East” or “E” preceding the street name and a suffix according to the standard. See signing below.

Numbered streets are south of State Avenue.

Short, private, dead-end streets will end in “Lane.” When possible, lanes will be named so that the sound of the first syllable matches the sound of the first syllable of the main abutting street to simplify finding small private roadways. If no syllable can be matched, the first letter may be used. (i.e. Murray Lane on Murdock)

Address numbers increase away from the dividing lines cited above. Odd numbered addresses are on the south and east sides of streets. This is contrary to the County addressing system, which has odd numbers on the north and east. An address number will be assigned to all new buildings at the time the Building Permit is issued. It is then the owner’s responsibility to see that the numbers are placed clearly and visibly at the main entrance to the property or at the principal place of ingress.

The developer must check with the Planning and Engineering Departments regarding the naming of streets. This should be done at the time the preliminary plat is

submitted and again upon approval of the final plat. The Planning and Engineering Departments will ensure that the name assigned to a new street is consistent with policies of the City.

3.2.4 Signing and Striping

- A. Street signs are defined as any regulatory, warning, or guide signs. The developer is responsible for providing all street signs. Developers may contact the Sedro-Woolley Street Department for assistance, and may have the City Street Department acquire the signs at the developer's expense. Street signs will comply with the latest editions of these standards, the **SWRS (under development)**, WSDOT Standards, and the U.S. Department of Transportation MUTCD.
- B. In general, 30-inch regulatory signs shall be used.
- C. The developer will provide pavement markings and street signs, including poles and hardware, under the City's direction to establish uniformity.
- D. New Crosswalks, turn arrows, and pavement legend installations shall be 3M "Stamark 420" pavement marking tape or equivalent, applied while the mat is still warm, and before traffic is allowed onto the new surfacing. MMA or 3M "Stamark 420 and/or 380" pavement marking tapes applied with 3M "P-50 Stamark Surface Preparation Adhesive" shall be used on roadways subjected to traffic for more than 3 days. Centerlines shall be "Stamark 380" or profiled MMA ("Durastripe") and shall include Type-2 raised pavement markers. Minor Collector streets shall be marked with stripes and Type-2 raised pavement markers per Standard Plans 3-17 & 3-18. Local streets need only crosswalks marked at intersections with arterial streets.
- E. Paint shall not be used for new street pavement markings. Thermoplastic shall only be used with prior approval of the Director of Public Works / City Engineer.
- F. Storm Drainage Markings shall be placed and maintained on roadway pavements where curb & gutter does not exist which represent locations of culverts, catch basins, and pipe intersections with pipe direction(s) indicated.
- G. Street name signs will display street names and orientation designation. Public Streets will be indicated by green signs with white lettering. Private Streets will be indicated by yellow signs with black lettering, and the letters "PVT" in the lower right-hand corner of the street sign. Street name signs shall be eight inches (8") tall with six inch (6") lettering, and minimum thirty inches (30") long, but sized to match the street name. See the street name sign detail in the appendix.
- H. Fire lane signage and markings shall be consistent with the 2003 International Fire Code, section D103.6. Fire lanes shall be posted "No Parking – Fire Lane" and "Tow Away Zone." Curbing shall be painted red for vertical curb applications, and/or a four-inch (4") continuous red stripe shall delineate the limits of the fire lane and the no parking zone.
- I. Signage and Striping plans shall show the locations of all mailboxes to be located/relocated, as well as bus stop signage and markings.
- J. Signage and Striping plans shall contain a signature block for the Postmaster, Skagit Area Transit (SKAT) and the Fire Chief.

3.2.5 Right-of-way

Right-of-way width is determined by the functional classification of a street, but shall

not be less than sixty feet (60') unless otherwise approved by the Public Works Director / City Engineer. See Minimum Street Design Standards Table 1. *See street section details for specific widths.*

Right-of-way requirements may be increased if additional lanes, pockets, transit lanes, bus loading zones, operational speed, bike lanes, utilities, etc. are required as determined by the Public Works Director / City Engineer.

Right-of-way will be conveyed to the City on a recorded plat or through a statutory warranty deed.

Landscaping shall provide headlight screening when needed as determined by the Public Works Director / City Engineer, and shall comply with SWMC Chapter 17.50.

Dedication Requirements:

If the right-of-way abutting the subject property has inadequate width based on classification and the current roadway standards or as determined by the Public Works Director / City Engineer, the applicant shall dedicate a portion of the subject property parallel to the right-of-way and equal in width to the difference between the present and required right-of-way width. The Public Works Director / City Engineer may waive dedication or permit dedication of a lesser amount if:

- A. It is likely that, within the near future, the private property across the right-of-way will be required to dedicate property for public right-of-way; or
- B. The reduction in the required right-of-way width will nonetheless provide adequate room for all improvements, infrastructure, and functions within the right-of-way.

For the purpose of determining rough proportionality of right-of-way dedication to the development's impacts, the City may require up to three hundred square feet (300 sq.ft.) of right-of-way dedication per average daily trip generated by the development.

3.2.6 Private Streets

Acceptance as Public Streets. Acceptance of existing private streets as public streets will be considered only if the streets meet all applicable public street standards, including right-of-way widths.

New private streets may be allowed at the Public Works Director / City Engineer's discretion. All private roads shall, at a minimum, meet City of Sedro-Woolley Public Works Standards for street, sidewalk and planter strip. Street lighting is required at the intersection of the private street with the public right-of-way, as well as within the privately owned, but publicly accessed portion of the project. Rights and responsibilities (Conditions, Covenants, and Restrictions) of each served property must be established by written document approved by the City Attorney and recorded in the County.

3.2.7 Street Frontage Improvements

- A. All new commercial and residential (including multi-family) development, plats, and short plats will install street frontage improvements at the time of construction as required by the Public Works Department. Such improvements

may include street widening, curb, gutter, sidewalk, handicap ramps, storm drainage, street lighting, planter strips, street trees, utility relocation or undergrounding, transit facilities, and traffic signal modification or installation. Plans will be prepared and signed by a licensed civil engineer registered in the State of Washington.

- B. Frontage improvements must be installed along the entire frontage and width of each right-of-way that abuts or traverses the subject property (SWMC). Tapers and transitions beyond the project frontage are required as deemed necessary for safety purposes. The taper rate shall be [Design Speed in MPH] : 1 (e.g. 35:1 on streets with a 35 mph design speed). The requirement may be reduced to half-street frontage improvements (centerline to right-of-way line) at the discretion of the Public Works Director / City Engineer, but in no case will less than a twenty foot (20') traveled way be provided.
- C. A remodel or redevelopment of existing structures or improvements will be required to install frontage improvements, provided that:
 - 1) Within any twelve (12) month period, the value of new improvements will exceed twenty-five percent (25%) of the assessed or appraised value (whichever is greater) of all existing structures on the property, and
 - 2) Public improvements have not been installed as part of any other Land Use Permit within the immediately preceding four (4) years.
- D. Sidewalks shall be installed along the frontage of properties subject to all land-use actions and/or building permits where the value of the improvement is \$20,000 or greater.
- E. Waiver, deferral, or modification of required frontage improvements may be requested. The criteria under which the request will be reviewed are:
 - 1. The improvement as required would not be harmonious with existing street improvements, would not function properly or safely or would not be advantageous to the neighborhood or City as a whole.
 - 2. Unusual topographic or physical conditions preclude the construction of improvements as required.
 - 3. Proper vertical or horizontal alignments cannot be determined because the existing streets do not have correct alignments.
 - 4. The required improvement is part of a larger project that has been scheduled for construction in the City's Capital Improvements Program.

Requests must be made in writing to the Deputy Public Works Director / City Engineer. A written response will be provided to the request. For single-family homes, there is a processing fee. If a deferral is granted, it is commonly accompanied by a condition that the applicant sign and notarize a Local Improvement District No-Protest Waiver Agreement. Recording Fees are the responsibility of the applicant.

- F. When street widening along the ROW frontage is required. Roadway reconstruction and/or pavement overlay to centerline will also be required for any of the following reasons, or when deemed necessary by the Public Works Director / City Engineer:
1. When adding to dissimilar pavement materials.
 2. If widening is less than two (2) feet.
 3. If any open cuts are required within the existing road surface.
 4. If a uniform two percent (2%) crown slope cannot be maintained.

3.2.8 Half Street

A half street is an otherwise acceptable roadway section modified to conform to limited right-of-way on the boundary of property subject to development. See definition in Section 1.

A half street may be permitted subject to approval by the Public Works Department when:

- A. There is reasonable assurance of obtaining the prescribed additional right-of-way from the adjoining property suitable for completion of a full-section roadway; and
- B. Such alignment is consistent with, or will establish, a reasonable circulation pattern; and
- C. The right-of-way width of the half street will equal at least thirty feet (30'), or fifty percent (50%) of the required right-of-way, whichever is greater; and
- D. The traveled way will be surfaced the same as the designated street classification to a width not less than twenty feet (20'); and
- E. The half street will be graded consistent with the centerline of the ultimate roadway section; and
- F. Property line edge of street will be finished with permanent concrete curb to insure proper drainage, bank stability, and traffic safety.

3.2.9 Medians

Medians ('boulevard' cross-section) may be required to improve traffic circulation and enhance right-of-way appearance. Medians shall be required if either of the following conditions are met:

- A. There are more than two (2) through traffic lanes in either direction.
- B. The roadway segment has a crash rate greater than ten (10) crashes per million vehicle miles as determined by the Public Works Director / City Engineer.

A median will be in addition to, not part of, the specified roadway width. Medians will be designed so as not to limit turning radius or sight distance at intersections. (Medians will be a minimum of four feet (4') wide.) Landscaping and irrigation are required. (See Appendix for approved plant list.) Water quality median swales are

encouraged. Edges shall be vertical barrier curb.

3.2.10 Intersections / Access

- A. Intersections and access locations shall be permitted only at locations where safe ingress / egress is proven.
- B. Only one access shall be allowed for any parcel or parcels under contiguous ownership or associated with a single project without explicit written consent from the Public Works Director / City Engineer. Exceptions are not likely unless access spacing is greater than 330' (1/16-mile).
- C. Accesses which force vehicles to back out onto a highway, principal arterial, secondary arterial, or collector arterial are prohibited. In these cases, vehicles shall be able to turn around clear of the right-of-way line.
- D. All access locations and new intersection locations shall be permitted through the City of Sedro-Woolley access permitting process.
- E. Traffic control will be as specified in the current edition of the MUTCD or as modified by the Public Works Director / City Engineer as a result of appropriate traffic engineering studies.
- F. Street intersections will be laid out so as to intersect as nearly as possible at right angles. Sharp angled intersections will be avoided. For safe design, the following types of intersection features should be avoided:
 - 1. Intersections with more than four (4) intersecting streets;
 - 2. "Y" type intersections where streets meet at acute angles;
 - 3. Intersections adjacent to bridges and other sight obstructions;
 - 4. The preferred angle of intersection is ninety (90) degrees. Deviations from ninety (90) degrees of more than ± 5 degrees will not be allowed without written modification request from the Public Works Director / City Engineer. In no case will the angle of intersection be less than seventy-five (75) degrees nor greater than one hundred-five (105) degrees.
 - 5. Offset intersections shall be avoided.
 - 6. For intersection of two local streets, the minimum allowable curb radius shall be thirty feet (30'), which is to be measured from the radius point to the face of curb. For the intersection of a local street with any collector or arterial, the minimum radius shall be thirty-five feet (35').

On all other street intersections, the minimum allowable radii shall be thirty-five feet (35'). Turning movement diagrams may be required to demonstrate appropriate radii have been designed. Turning movement diagrams are required when trucks larger than WB-40 will be regularly using the intersection.

- G. Spacing between adjacent intersecting streets, alleys, and driveways, will be per the Sedro-Woolley Access Management Standard found in Section 3.2.13.
- H. On sloping approaches at an intersection, landings will be provided with grade not to exceed one foot (1') difference in elevation for a distance of thirty (30) feet

(3.33%) approaching any arterial or twenty (20) feet (5%) approaching a minor collector or local access street, measured from nearest right-of-way line (extended) of intersecting street.

- I. All points of access to the public street system shall be permitted using a City of Sedro-Woolley Access Permit.
- J. Whenever possible and to the greatest degree possible, access shall be shared ingress/egress to the public streets, and mutual ingress/egress access between businesses, parcels, parking lots, and buildings shall be provided within the commercial/industrial zones.
- K. All abandoned driveway areas on the same frontage shall be removed and the curbing, sidewalk, shoulders, ditch section, etc. shall be properly restored.

3.2.11 Street Layout

No street or combination of streets shall function as a cul-de-sac or dead-end longer than three hundred feet (300') without written modification approval from the City Engineer / Director of Public Works.

Temporary or permanent dead-end streets shall have an approved turn-around area (cul-de-sac) for emergency vehicles. The maximum length for a cul-de-sac street shall be three hundred feet (300') without written modification from these standards.

Hammerhead turnarounds may be used on streets that exceed one hundred fifty feet (150') and provide access to four (4) or less lots.

Emergency vehicle turnarounds shall comply with the International Fire Code, section D103.1.

Block perimeters shall be no greater than 1,760 feet (1/3 mile), as measured on center lines.

Exceptions to the block perimeter standards may be granted due to topographical constraints, environmentally sensitive areas, and adjacent development not being conducive.

An arterial grid pattern of no more than 2,640 feet (1/2 mile) shall be maintained in new development and re-development throughout the City.

A minor collector grid pattern of no more than 1,320 feet (1/4 mile) shall be maintained in new development and re-development throughout the City.

Existing arterial/collector street patterns shall be extended wherever logical. Extensions/improvements of streets which line up with arterial/collector roads shall be improved to match the classification of the existing roadway.

A local street grid pattern of 330' (16 per mile) - 528' (10 per mile) is encouraged.

Streets on steep slopes should be designed to be generally parallel, rather than perpendicular, to the slope. Maximum slope is 12%

All newly created residential lots should abut a public street right-of-way. Direct access onto arterial streets is prohibited, unless no reasonable alternative exists.

3.2.12 Alleys

The pavement width of an alley shall be no more than eighteen feet (18'), with a minimum twenty foot (20') right-of-way.

Dead-end alleys shall be avoided. If unavoidable, turn-around facilities shall be provided when the alley is longer than one hundred fifty feet (150').

The length of an alley shall be no more than three-hundred thirty feet (330') if dead-end, and five-hundred twenty-eight feet (528') if access is provided at both ends.

3.2.13 Driveways

A. General

1. Details of driveway sections are located in the Appendix.
2. All abandoned driveway areas on the same frontage shall be removed and the curbing and sidewalk or shoulder and ditch section shall be properly restored.
3. All driveways shall be constructed of Portland Cement Concrete and will be subject to the same testing inspection requirements as curb, gutter, and sidewalk construction.
4. Joint-use driveways serving two or more adjacent parcels are encouraged, and may be built on their common boundary. For the protection of all parties, it will be necessary to obtain a mutual ingress/egress easement agreement signed by all property owners and approved by the City. The agreement will be a recorded easement for all parcels of land specifying joint usage. The City can provide an example easement format.
5. Grade breaks, including the tie to the roadway, will be constructed as smooth vertical curves. The maximum change in driveway grade will be eight percent within any ten feet of distance on a crest and 10 percent within any ten feet (10') of distance in a sag vertical curve.
6. No driveway, other than one serving a detached dwelling unit, will be approved where backing onto the sidewalk or street will occur.
7. Where driveways cross sidewalks, the thickness of the concrete shall not be less than six inches (6") and shall contain welded wire fabric (WWF) reinforcement.

B. Width

1. For driveways that serve only single-family residential uses, the maximum driveway width is the greater of 24 feet (24') for a two-way driveway, or ten feet (10') for each parking stall, and twelve feet (12') for a one-way driveway, but may not exceed thirty feet (30') at the front property line.
2. For driveways that serve uses other than single-family residential uses, driveway width shall be minimum twelve feet (12') and maximum twenty feet (20') for a one-lane, one-way driveway, minimum twenty-four feet (24') and maximum thirty feet (30') for a two-lane, two-way driveway, and minimum thirty-three feet (33') and maximum forty feet (40') for a three-

lane, two-way driveway. Driveway widths may be increased in order to provide adequate width for vehicles that may be reasonably expected to use the driveway, as determined by the Public Works Director / City Engineer.

C. Driveway / Throat Length

- A. For driveways serving commercial or industrial property off of an arterial (principal or secondary) the throat length shall be a minimum of one-hundred feet (100'). The intent is to allow a combination truck-trailer to follow a passenger car into the driveway without having to stop in the traffic lane(s).
- B. For driveways serving commercial or industrial property off of a collector arterial, the throat length shall be a minimum of seventy-five feet (75') in order to allow a combination truck-trailer to pull into the driveway without having to stop in the traffic lane(s).
- C. For driveways serving residential property off of an arterial (principal or secondary) or a collector arterial, the minimum length is thirty feet (30'), and shall provide a turn-around area outside of the right-of-way.

D. Arterial and Collector Arterial Streets

- 1. Access to arterials and collector arterials may be permitted consistent with the following table. On state highways that are not designated as limited access, the minimum spacing is two hundred fifty feet (250'), or as shown in the following table, whichever is greater. Left-turn and crossing movements through standing queues of traffic may be prohibited, as determined by the Public Works Director / City Engineer.
- 2. Driveways that serve any use other than detached dwelling units may not be located closer than one hundred sixty five feet (165', 32 per mile) to any street intersection or to any other driveway, whether on or off the subject property. Driveways that serve only residential use may not be located closer than twenty-five feet (25') to any street intersection.
- 3. There may be no more than one driveway for each three hundred thirty feet (330') of lot frontage (16 per mile). The City may further limit or prohibit access to or from driveways onto arterial and collector arterial streets.
- 4. Separation distances shall be measured from centerline to centerline of roadways and driveways.
- 5. Driveways giving direct access onto arterials or collector arterials may be denied if alternate access is available. The Public Works Director / City Engineer may permit modifications from these standards.

City of Sedro-Woolley Access Management Standards

Access Classification	Median	Through Traffic Lanes	Crossing Movements	Minimum Spacing (feet)**				Minimum Signal Progression Efficiency***
				Left-Turn Out	Left-Turn In	Right-Turn Out	Right-Turn In	
1	Raised	6	Only at signalized intersections	Only at signalized intersections	330	165	165	40%
2	Raised	4	330	330	330	165	165	30%
3	2-Way Left Turn Lane	4	165	165*	165*	165*	165*	20%
4	2-Way Left Turn Lane	2	165*	165*	165*	165*	165*	10%

*Does not apply to single-family residential uses

**Greater spacing may be required in order to minimize conflicts with queued traffic.

***If the existing efficiency is less than the standard, new traffic signals may not reduce the existing efficiency.

3.2.14 Sight Obstructions

The following sight clearance requirements take into account the proportional relationship between speed and stopping distance.

The sight distance area is a clear-view triangle formed on all intersections by extending two lines of specified length right and Left as shown below from the intersecting street along the centerline of the through street and connecting those endpoints to form the hypotenuse of the triangle. The area within the triangle will be subject to restrictions to maintain a clear view on the intersection approaches.

Intersection Sight Distance Triangle:

A. Stop or Yield Controlled Intersection

Providing adequate sight distance from a street or driveway is one of the most important considerations in ensuring safe street and driveway operation. The WSDOT Design Manual criteria given in Figures 910-16a and 16b below must be used to determine the minimum sight distance along the through roadway. If the proper sight distance cannot be achieved using the WSDOT Design Manual, than the AASHTO publication entitled *A Policy on Geometric Design of Highways and Streets* (“Green Book”) may be used. When designing intersections for commercial streets the AASHTO method must be used.

Supporting data and calculations for intersection sight distance must be submitted with the street plans for review.

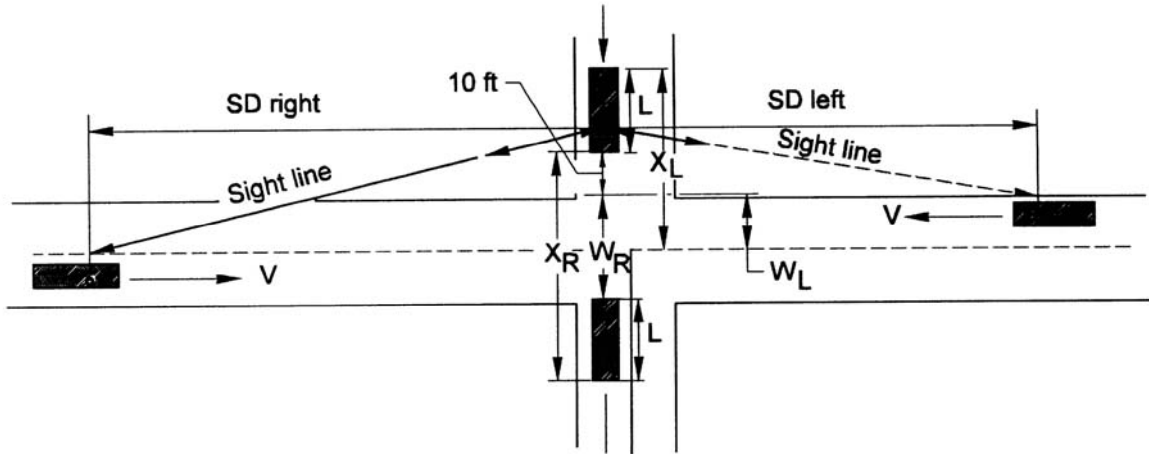

SIGHT DISTANCE FOR GRADE INTERSECTION WITH STOP CONTROL

SD = Sight Distance
 t_a = Time for acceleration
 V = Design speed on the through highway
 L = Length of vehicle
 X = Length of vehicle travel

Note: If the crossroad is not level, multiply t_a by the adjustment factor to consider the grade.

L Values	
P =	19 ft
SU =	30 ft
WB 50 =	55 ft
WB 67 =	73.5 ft

Sight Distance Adjustment Factor					
Design Vehicle	Crossroad Grade, Percent				
	-4	-2	0	+2	+4
P	0.7	0.9	1.0	1.1	1.3
SU	0.8	0.9	1.0	1.1	1.3
WB 40	0.8	0.9	1.0	1.2	1.7

EXAMPLE:

Given:

Two – 12 ft lanes to be crossed by a WB-50
 Intersection angle approximately 90°
 Through highway design speed = 70 mph

Find:

The minimum required sight distance.

Solution:

$$X_{right} = 10 \text{ ft} + W_R + L = 10 \text{ ft} + 24 \text{ ft} + 55 \text{ ft} = 89 \text{ ft}$$

$$X_{left} = 10 \text{ ft} + W_L + L = 10 \text{ ft} + 12 \text{ ft} + 55 \text{ ft} = 77 \text{ ft}$$

From the charts as shown, the required minimum SD = 1,260 ft right and 1,180 ft left.

SIGHT DISTANCE FOR GRADE INTERSECTION WITH STOP CONTROL

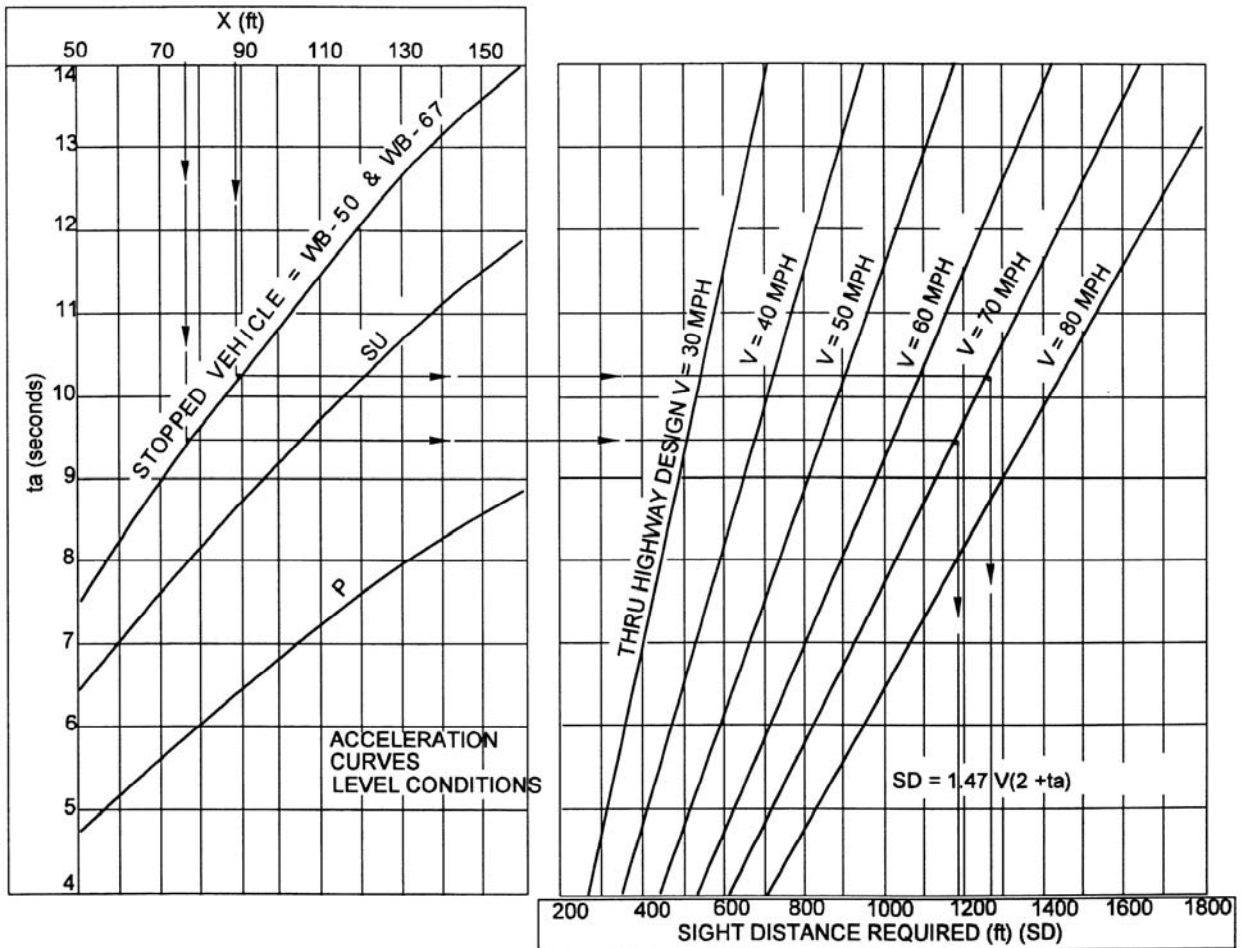

B. The vertical clearance area within the sight distance triangle will be free from obstructions to a motor vehicle operator's view between a height of 2.5 feet (2.5') and ten feet (10') above the existing surface of the street.

C. Exclusions

The following are permitted to be within the area that must be clear of sight obstructions:

1. Any structure erected before the effective date (5-31-03)
2. Natural topography of the ground. However, the Public Works Director / City Engineer may require land surface modification to fulfill the intent of this division of the SWPWDS as part of any development activity on the subject property.
3. Any number of tree trunks, sign poles or utility poles if the Public Works Director / City Engineer determines that adequate visual access is available between them.

3.2.15 Surfacing Requirements

The following are the surfacing requirements for each application listed.

The minimum pavement sections listed in the street standard plans are in lieu of pavement design; and are based on subgrade California Bearing Ratio value of three (CBR = 3). Alternate pavement sections will be accepted based on soil tests to determine the actual CBR value and traffic counts, truck percentages, and twenty (20) year design life. Soil tests and a pavement design for each road classification will accompany plans submitted if other than the sections shown below are used.

Fire access lanes shall be designed with an all-weather surface so that the pavement section can withstand loading pressure of 90 psi. Fire access lanes that are not part of required circulation or parking may be paved with grass grid pavers or other low-impact design, provided they meet the minimum loading pressure.

One (1) soil sample per each five hundred (500) LF of centerline with three (3) minimum per project representative of the roadway subgrade will be taken to determine a statistical representation of the existing soil condition.

An engineering firm specializing in soils analysis shall perform soil tests.

A soils report, signed and stamped by a professional engineer licensed by the State of Washington, shall be based on actual soils tests and submitted with the plans. All depths indicated are a minimum compacted depth.

Parking areas, driveways and other vehicular circulation areas must be surfaced with a material comparable or superior to the surface material of the adjacent right-of-way. The first forty feet (40') of an access driveway must meet the standards described above.

Note that after April 1, 2006, all City projects shall use the new (current) HMA (hot mix asphalt) specifications in the 2006 or later Standard Specifications for Road, Bridge, and Municipal Construction.

All subgrade compacted to 95% modified proctor.

A. Sidewalks

Surfacing: 4" Commercial Concrete, 3000 psi or better (6" concrete where driveway crosses, and 6" reinforced commercial concrete when at highway, arterial, or collector arterial intersection)

Base: 2" Crushed Surfacing Top Course (4" C.S.T.C. when at highway, arterial, or collector arterial intersection)

Asphalt sidewalks will not be permitted unless otherwise approved by the Public Works Director / City Engineer.

Alternate:

Low-impact development (LID) designs are encouraged. Please present your LID alternate design to the Public Works Department.

Joints: Expansion joints every fifty feet (50') filled with standard one-half inch (1/2") joint filler material.

Contraction joints every five feet (5') to make standard five-foot long panels.

B. Driveway

Residential

Surfacing: 6" Commercial Concrete

Base: 2" Crushed Surfacing Top Course
(4" C.S.T.C. if subject to commercial traffic)

Alternate:

Low-impact development (LID) designs are encouraged. Please present your LID alternate design to the Public Works Department.

Non-Residential

Surfacing: 6" Commercial Concrete

Base: 4" Crushed Surfacing Base Course

C. Non-Motorized Path

Surfacing: 4" Commercial Concrete
(6" if over utility easement or heavy loads are expected)

Base: 2" Crushed Surfacing Top Course

Alternate:

Surfacing: 2-1/2" Class 1/2" PG 64-22 HMA or Class B Asphalt Concrete
(3" Class B if over utility easement or heavy loads are expected)

Base: 4" Crushed Surfacing Top Course
(6" C.S.T.C. if heavy loads are expected)

Alternate:

Low-impact development (LID) designs are encouraged. Please present your LID alternate design to the Public Works Department.

D. Minimum Pavement Section

1. Principal Arterial

Surfacing: 4" Class ½" PG 64-22 HMA or Class B Asphalt Concrete (in 2-2" lifts)
Base: ▪ 9" Class E Asphalt Concrete (3" max lifts) over
 ▪ 6" C.S.T.C.
Subbase: 12" Pit Run / Bank Run or thickness to be determined by design.

Alternate:
Surfacing: 8" Class ½" PG 64-22 HMA or Class B Asphalt Concrete (3" max lift thickness)
Base: 9" C.S.B.C.
Subbase: 18" Pit Run / Bank Run or thickness to be determined by design.

Alternate:
Surfacing: 4" Class ½" PG 64-22 HMA or Class B Asphalt Concrete (in 2-2" lifts)
Base: ▪ 6" Asphalt Treated Base (ATB)
 ▪ 12" C.S.B.C.
Subbase: 12" Pit Run / Bank Run or thickness to be determined by design.

2. Minor Arterial

Surfacing: 8" Class ½" PG 64-22 HMA or Class B Asphalt Concrete.
Base: 6" Class E Asphalt Concrete
or:
 ▪ 3.5" Class B Asphalt Concrete over
 ▪ 10" Asphalt Treated Base
Subbase: 12" Pit Run / Bank Run or thickness to be determined by design.

3. Collector Arterial

a. Commercial/Industrial/Multi-family

Surfacing: 6" Class ½" PG 64-22 HMA or Class B Asphalt Concrete.
Base: 6" of ATB and/or Crushed Surfacing.
(Thickness to be determined by design with minimum thickness of 8" if no ATB is used).
Subbase: 12" Pit Run / Bank Run or thickness to be determined by design.

b. Single Family

Surfacing: 4" Class ½" PG 64-22 HMA or Class B Asphalt

Concrete.
Base: 6" of ATB and/or Crushed Surfacing.
(Thickness to be determined by design with minimum thickness of 8" if no ATB is used).
Subbase: 12" Pit Run / Bank Run or thickness to be determined by design.

4. Minor Collector

Surfacing: 3" Class ½" PG 64-22 HMA or Class B Asphalt Concrete
Base: 2" Crushed Surfacing Top Course
6" Crushed Surfacing Base Course
Subbase: 9" Pit Run / Bank Run min. as necessary to stabilize pavement.

5. Local Street - Residential

Surfacing: 3" Class ½" PG 64-22 HMA or Class B Asphalt Concrete
Base: 2" Crushed Surfacing Top Course
5" Crushed Surfacing Base Course
Subbase: 8" Pit Run / Bank Run min. as necessary to stabilize pavement.

Alternate:

Low-impact development (LID) designs are encouraged. Please present your LID alternate design to the Public Works Department. The City has done an experimental pervious asphalt intersection at F&S Grade Road and West Jones/Klinger Street.

E. Pavement Construction

All pavement construction shall be in accordance with the Standard Specifications except as modified herein.

1. Compaction tests shall be performed by an approved geotechnical or testing firm under the direction of a professional civil engineer registered in the State of Washington.
2. Class ½" PG 64-22 HMA, Asphalt Concrete Class A, B, D, E, & F shall be compacted in lifts not to exceed three inches (3") unless approved by the Director or his designated representative. Density shall be at least 91% of maximum theoretical density (Rice Density). Asphalt concrete Class E shall be compacted in lifts not the exceed four inches (4").
3. Base Course (crushed surfacing) shall be compacted in depths not to exceed four inches (4") except top course shall be two inches (2") unless otherwise directed. Density shall be at 95% of ASTM D 1557.
4. Pit Run / Bank Run (gravel base) shall be compacted in depths not to exceed nine inches (9") unless otherwise directed. Density shall be at least 95% of ASTM D 1557. Pit Run / Bank Run (gravel base) materials shall meet WSDOT requirements.
5. Asphalt treated Base (ATB) shall be compacted in depths not to exceed four inches (4") unless otherwise directed. Density shall be at least 80% of maximum theoretical density (rice density) of the mix established by

WSDOT FOP for AASHTO T 209. ATB shall meet WSDOT requirements.

6. The prepared subgrade shall be compacted in the top six inches (6") to 95% of ASTM D 1557 for a cut section. If the underlying subgrade is too soft to permit compaction of the upper six-inch layer, the contractor shall loosen (or excavate and remove), and compact the subgrade until the top layer can meet compaction requirements. Fill sections shall be prepared in accordance with the Standard Specification Section 2-03. (14) C, Method B except ASTM D 1557 shall determine the maximum density.
7. Where asphalt concrete is placed in lifts, tack coat shall be used unless the lifts are placed on the same day and approved by the Public Works Director / City Engineer.
8. In areas where soft subgrade requires stabilization, approved geofabric may be used and/or soil stabilizing may be used. Ballast material may be used where necessary as directed by the engineer.

F. Materials

1. All materials used for road construction shall be in accordance with the applicable sections of the WSDOT Standard Specifications and as modified herein.
2. If other materials than those specified are used or concrete pavement is designed, criteria and procedures shall be approved by the Public Works Director / City Engineer.
3. Recycled materials for the pavement sections shall only be allowed by permission from the Public Works Director / City Engineer. The decision to use such materials under varying site conditions is final.

3.2.16 Road and Sidewalk Cuts

All road and sidewalk cuts within public right-of-way shall require a right-of-way permit and road cut permit.

- A. Road Cut Moratorium. Pursuant to Ordinance 1360-00 and SWMC 15.40, except for emergency situations, it is City policy to disallow open cuts made to the surfacing of any public roadway or sidewalks for the periods stated below:

Pavements:

1. Seven- (7) years immediately following new construction or reconstruction.
2. Five- (5) years immediately following major resurfacing, (greater than 1.5 inches of new surfacing) this does not include surface treatments such as BST, chip seal, fog seal, slurry seal, etc.
3. Two- (2) years immediately following a surface treatment such as BST, chip seal, fog seal, slurry seal, etc.

Sidewalks:

4. Five- (5) years immediately following a new sidewalk installation, such as in a new subdivision. Exception: Mitigation by placement /

replacement of other sidewalks in the City to the satisfaction of the Public Works Director / City Engineer.

5. Two- (2) years immediately following a municipally funded sidewalk replacement / repair. Exception: Mitigation by placement / replacement of other sidewalks in the City to the satisfaction of the Public Works Director / City Engineer.
 6. All new sidewalk installations involving an intersection or near an intersection shall be responsible for installing new ADA acceptable ramps with truncated domes detectable warning devices.
- B. If an open cut is allowed to a public roadway, all joints shall be saw cut prior to patching, and an approved crack sealer shall be used to seal all cracks and joints in the vicinity of the roadway cut(s). Crack sealant shall be rubberized asphalt as specified in WSDOT/APWA Standard Specifications Section 9-04.10 (ASTM D-1190) unless approved by Public Works Director or City Engineer. Plain emulsified asphalt, or "tack" is not an acceptable substitute.
- C. If an open cut is allowed in a cut moratorium section of pavement, the minimum mitigation is to repave $\frac{1}{2}$ the width of the paved surface for a length of one hundred feet (100') unless the road cut crosses over the centerline, which will require repaving the full-width for a length of one hundred feet (100'). Actual mitigation shall be determined by the Public Works Director / City Engineer.
- D. Temporary restoration of trenches will be accomplished by using minimum two inches (2") Class B Asphalt Concrete Pavement when available, or two inches (2") medium-curing (MC-250) Liquid Asphalt (cold mix), U.P.M., two inches (2") Asphalt Treated Base (ATB), or steel plates.
- E. ATB used for temporary restoration may be dumped directly into the trench, bladed and rolled. After rolling, the trench must be filled flush with asphalt concrete pavement to provide a smooth riding surface.
- F. Prior to beginning street trenching work, the contractor will ensure that temporary patching material is stockpiled at the project site, both for completing and maintaining the patching.
- G. All temporary patches will be maintained by the contractor and will be made permanent within three (3) working days, unless approved otherwise by the Public Works Department. Patches that are not properly maintained will be identified by the City Construction Inspector and repaired by the City at the developers/contractors expense.

H. Road Cut Permits:

1. All work performed in a public right-of-way shall require the issuance of a right-of-way and street/road cut permit. Permits shall be obtained forty-eight (48) hours prior to construction (except as noted in paragraph 3).
2. The work of installing range boxes, surveying monuments, adjusting manhole rings and service boxes, or any similar work undertaken solely for the convenience of and at the order of the City shall require a permit; however the permit shall be issued on a "NO FEE" basis. The permittee will still be required to perform his work in complete compliance with all City standards and requirements.

3. Permits shall apply to emergency repairs; however, a delay of 48 hours is granted, excluding weekends and holidays, following the beginning of such repair before the permit for the same shall become a penalty permit.
4. Any permit issued shall pertain only to excavating or constructing within the City right-of-way and is in no way a permit to enter any private property adjacent to such right-of-way or easement or to alter or disturb any facilities or installations existing within the right-of-way and which may have been installed and are owned by others.
5. No permit shall be issued to any person or corporation except as set forth in paragraph 4.
6. Permits, when issued, shall be valid for a period of ninety (90) calendar days, and may be renewed for one (1) additional ninety (90) calendar day period, providing the renewal is obtained (renewal may be obtained by telephone or fax) prior to the expiration date of the permit. Failure to obtain a renewal as stated herein will require the obtaining of a new permit and payment of all applicable fees.
7. Any permit determined to be without an adequate bond as required in paragraph 4, shall be subject to immediate revocation by the City.
8. Failure of the applicant to comply with any of the terms and conditions of the permit shall be sufficient cause for cancellation of the permit and may be cause for the refusal of future permits. The permit, the privileges granted by the permit, and the obligations of the permittee shall be binding upon the successors and subcontractors of the permittee.
9. The City Inspector is authorized to inspect all work performed under the permit, including, but not limited to clearing and grubbing, compaction of subgrade, base and asphalt, forms, concrete work, structures, and materials to be used. The Inspector may be present on the site to advise contractors of these standards. The Inspector has authority to reject defective materials and workmanship.
10. No permits will be issued for roadway cuts on newly paved or overlaid roads for a period of seven (7) years, unless approved in writing by the Public Works Director / City Engineer. Services to new construction will be evaluated case by case. Emergency cuts will be permitted in accordance with paragraph 3.
11. The permittee shall submit plans to the City for approval for all projects in excess of \$10,000 in value. These plans are to be submitted prior to the pre-construction meeting and shall adhere to all City standards and policies.
12. Surveyors shall be responsible for obtaining a permit when setting new monumentation within City Right-of-Way or when replacing existing monumentation. Permits are not required for accessing existing monumentation, however, the Surveyor is responsible for repair of damages to the roadway.
 - I. If potholes are required to verify utility crossing depths and allowed to avoid an open cut, all utility potholing shall be done by vactor method, six-inch (6") or eight-inch (8") diameter, and backfilled to within six inches (6") of the top with CDF, and capped with six inches (6") of 3000 psi early strength concrete.

3.2.17 Trench Backfill and Restoration

Trench restoration will be done by a patch, patch plus overlay, or lane

reconstruction as required by the City. See trench repair details 3-2-17a, 3-2-17b, and 3-2-17c.

- A. All trench and pavement cuts will be made uniformly by saw-cutting. If edge of trench line degrades, ravel, or is non-uniform, additional saw-cutting is required prior to final patch or paving. The minimum width for asphalt patching will be three feet (3') for transverse and longitudinal trenching.
- B. All crushed surfacing materials will conform to Section 9-03.19 of the WSDOT/APWA Standard Specifications. The trench will be compacted to 95 percent maximum density, as described in Section 2-03 of the WSDOT/APWA Standard Specifications.

All granular backfill material will conform to Section 9-03.19 of the WSDOT/APWA Standard Specifications. The trench will be compacted to 95 percent maximum density, as described in Section 2-03 of the WSDOT/APWA Standard Specifications. Compaction testing shall be performed by an independent geotechnical / materials testing firm at a frequency of not less than one hundred feet (100'). More frequent testing may be required by the City, at the Public Works Director / City Engineer / City Inspector's discretion.

If the existing material is determined by the City to be suitable for backfill, the contractor may use the native material except that the top eight inches of trench will be 2½-inch minus ballast. All trench backfill materials below the roadway base and sub-base level will be compacted to 95 percent density.

When trench width is eighteen inches (18") or less, and is within the traveled way, trench will be backfilled with 150 p.s.i. controlled density fill (CDF, CLSM [Controlled Low-Strength Material], flowable fill).

Backfill compaction and placement will be performed in compliance with WSDOT/APWA Standard Specifications. All perpendicular crossings of the roadway will be backfilled 100% with CSTC.

Replacement of the asphalt concrete or Portland Cement Concrete pavement will be to WSDOT/APWA Standard Specifications.

- C. Tack will be applied to the existing pavement and edge of cut and will be emulsified asphalt grade CSS-1 as specified in Section 9-02.1(6) of the WSDOT/APWA Standard Specifications. Tack coat will be applied as specified in Section 5-04 of the WSDOT/APWA Standard Specifications.
- D. Asphalt concrete will be placed on the prepared surface by an approved paving machine and will be in accordance with the applicable requirements of Section 5-04 of the WSDOT/APWA Standard Specifications, except that longitudinal joints between successive layers of asphalt concrete will be displaced laterally a minimum of twelve inches (12") unless otherwise approved by the Public Works Director / City Engineer. Fine and coarse aggregate will be in accordance with Section 9-03.8 of the WSDOT/APWA Standard Specifications. Asphalt concrete over three inches thick will be placed in equal lifts not to exceed three inches each.

All street surfaces, walks, or driveways within the street trenching areas affected by the trenching will be feathered and shimmed to an extent that

provides a smooth-riding connection and expeditious drainage flow for the newly paved surface. Shimming and feathering as required by the Public Works Director / City Engineer will be accomplished by raking out the oversized aggregates from the Class B mix as appropriate. Surface smoothness will be per Section 5-04.3 (13) of the WSDOT/APWA Standard Specifications. The paving will be corrected by removal and repaving of the trench only.

Asphalt concrete pavement for permanent wearing course will not be placed on any traveled way between October 1st and April 30th without written approval from the Public Works Director / City Engineer.

Asphalt for prime coat will not be applied when the ground temperature is lower than 50° F, without written permission of the Public Works Director / City Engineer.

Asphalt concrete will not be placed on any wet surface, or when the average surface temperatures are less than those specified in Section 5-04.3(16) of the WSDOT/APWA Standard Specifications, or when weather conditions otherwise prevent the proper handling or finishing of the bituminous mixtures:

Section 5-04.3(16) – WSDOT/APWA Standard Specs

Compacted Thickness (ft.)	Surface Temperature Limitations	
	Surface Course	Sub-Surface Course
Less than 0.10	55° F	55° F
0.10 to 0.20	45° F	35° F
0.21 to 0.25	35° F	35° F

- E. All joints on trenching or overlays shall be sealed using rubberized asphalt as specified in WSDOT/APWA Standard Specifications Section 9-04.10 (ASTM D-1190) unless approved by Public Works Director or City Engineer.
- F. When trenching within the roadway shoulder(s), the shoulder shall be restored to its original or better condition.
- G. The final patch will be completed as soon as possible and will be completed within three days after first opening the trench. This time frame may be adjusted if delays are due to inclement paving weather, or other adverse conditions that may exist. However, delaying of final patch or overlay work is allowable only subject to the Public Works Director / City Engineer's approval. The Public Works Director / City Engineer may deem it necessary to complete the work within the three days time frame and not to allow any time extension. If this occurs, the Contractor will perform the necessary work as directed by the Public Works Director / City Engineer.
- H. For longitudinal utility trench cuts, the City requires matching the existing pavement section or a minimum two-inch (2") asphalt overlay, whichever is more, after trench pavement restoration or pavement reconstruction when trench cut or patch is within one travel lane.

3.3 SIDEWALKS AND CURBS

3.3.1 Design Standards

Plans for the construction of sidewalks and curbs are to be submitted as part of the street plans when applicable.

The City has set forth minimum standards as outlined in the Appendix that must be met in the design and construction of sidewalks and curbs. Because these are minimum standards, the Public Works Director / City Engineer may modify them should the Director feel circumstances require increased or decreased widths.

3.3.2. Sidewalks

Sidewalks used in conjunction with vertical curb shall be constructed of commercial concrete four inches (4") minimum thickness on two-inch (2") minimum CSTC, except where driveways cross the sidewalk, which shall be six inches (6") minimum thickness on two-inch (2") minimum CSTC. When the sidewalk and curb are contiguous, the width of the sidewalk will be measured from back of curb to back of sidewalk.

Sidewalks used in conjunction with rolled curb, no curb, or otherwise subject to occasional vehicular loadings shall be constructed of commercial concrete six inches (6") minimum thickness on two-inch (2") minimum CSTC.

Sidewalks at highway, arterial, or collector arterial intersections shall be designed and constructed of reinforced commercial concrete, six inches (6") minimum thickness on four-inches (4") minimum thickness CSTC between the PC and PT of the curb return unless the intersection is designed with a WB-67 design vehicle at 4 mph, not crossing into lanes of opposing traffic, and outside wheel tracks are a minimum of 12 inches (12") from the curb during turning maneuvers.

The width of sidewalks will be shown in the street design drawings. Those sidewalks designated in the comprehensive bike plan of the City as bike paths will, in addition, meet the minimum width requirements established for said bike paths. The Public Works Director / City Engineer will require that the design of all sidewalks provide for a gradual, rather than an abrupt, transition between sidewalks of different widths or alignments.

- A. All new sidewalks, including driveway sections, shall conform to current ADA standards, including ADA acceptable wheelchair ramps with truncated domes detectable warning devices. See section 3.3.4.
- B. Form and subgrade inspection by the City is required before sidewalk is poured.
- C. Monolithic pour of curb and sidewalk will not be allowed.
- D. For driveway requirements, see Section 3.2.13.

3.3.3 Curb

Cement concrete curb will be used for all street edges unless otherwise approved by the Public Works Director / City Engineer, or where ditch sections are approved. All curbs will be constructed of Commercial Concrete as shown on Detail 3-4.

Curb at highway, arterial, or collector arterial intersections shall be designed and constructed of reinforced commercial concrete between the PC and PT of the curb return, unless the intersection is designed with a WB-67 design vehicle at 4 mph, not crossing into lanes of opposing traffic, and outside wheel tracks are a minimum of 12 inches (12") from the curb during turning maneuvers.

Form and subgrade inspection by the City are required before curb and gutter are poured.

3.3.4 Curb Access Ramps

All sidewalks shall be constructed to provide for access ramps in accordance with the standards of the Americans with Disabilities Act and Washington State Barrier-Free code (WAC 51-30). Construction shall conform to **WSDOT Standard Plans F-3a Type 1B, Layout 3 or F-3e, Type 4B ONLY**, modified so that areas within the ramp which are not covered by truncated domes or edging are covered with standard 'diamond' expanded metal grating hatch pattern. Other types of ramps will be permitted only on a case by case basis, through written modification request and approval.

Access ramps shall be provided on each quadrant of an intersection from which pedestrian movement is permitted. They shall be oriented in the same direction as the pedestrian flow within crosswalks. Visual and tactile cues (Truncated Domes) shall also be oriented in the same direction as the pedestrian flow within crosswalks, and shall be 24" in 'depth.' Diagonally oriented curb ramps are prohibited.

Truncated Domes shall be permanent yellow in color and have the maximum spacing and minimum size dimensions as shown in WSDOT Standard Plans F-3a and F-3e, as follow:

- A = 2-3/8"
- B = 1-1/2"
- C = 7/16"
- D = 7/8"

3.3.5 Staking

All surveying and staking will be performed by engineering or surveying firm capable of performing such work. The engineer or surveyor directing such work will be licensed by the State of Washington.

At the Pre-construction Meeting, the City will discuss staking requirements. The City may inspect construction staking prior to construction.

The minimum staking of curb and sidewalk will be as follows:

- A. Stake top back of sidewalk or top face of curb at a consistent offset for vertical and horizontal alignment every twenty-five feet (25') (fifty feet

(50') in tangent sections).

- B. Staking will be maintained throughout construction.

3.3.6 Testing

Testing will be required at the developer or contractor's expense on all materials and construction as specified in the WSDOT/APWA Standard Specifications.

3.4 BIKEWAYS

3.4.1 Design Standards

The design of bicycle paths will depend upon their type of usage. Bikeway surfacing will be as outlined in Section 3.2.15.

All minimum design standards as set forth in Section 3.2.15(E) will apply.

The minimum design standards for bikeways will be as defined in the "WSDOT Design Manual," Section 1020, Facilities for Non-Motorized Transportation.

Bikeways are categorized as follows:

- A. **Class I, Bike Path** – A separate facility for use principally by bicyclists, but may be shared with pedestrians. These facilities are separated from motor vehicle roadways.
- B. **Class II, Bike Lane** – A portion of the motor vehicle roadway that is designated by signs and pavement markings for bicycle use. These facilities are adjacent to the motor vehicle roadway.
- C. **Class III, Bike Route** – A street that is designated with signs as a bicycle route, where bicycle usage is shared with motor vehicles on the street or, less desirably, with pedestrians on a sidewalk or walkway.
- D. Class I, II, or III Bikeways as appropriate, will be provided:
 - 1. Wherever called for in the Sedro-Woolley Comprehensive Plan. (See the City of Sedro-Woolley adopted 'Bike Routes and Trails in the City of Sedro-Woolley.
 - 2. When traffic analysis or planning indicates substantial bicycle usage that would benefit from a designated bicycle facility as determined by the City except where noted herein.

3.5 PLANTER STRIP

The planter strip shall be the width specified in the Street Section Details, and shall be landscaped with a minimum of twelve inches (12") sandy-loam soil underlying street trees and sod grass. An underground irrigation system is required. Following installation, it is the responsibility of the developer to maintain the planter strip in a healthy, growing condition during the two (2) year maintenance period.

Within the Central Business District (CBD), planter strips are not required, except on State Street. Instead, trees shall be placed in four-foot by six-foot tree grates alternating with pedestrian streetlights. Detail 3-30 provides spacing and dimensions. Plantings within the

pedestrian street light planter well shall be as specified in the Appendix.

3.5.1 Street Trees

The recommended trees and minimum spacing between them is shown in the City of Sedro-Woolley Urban Forestry Manual, July 2003. Spacing is approximate – exact spacing will depend on locations of streetlights, fire hydrants, driveways, sight clearance triangles, etc., but in general, 30’ spacing is desired.

Street trees shall be selected from the approved species list shown in the City of Sedro-Woolley Urban Forestry Manual, July 2003 and shall be placed on twenty-five (25) to thirty-five (35) foot centers. At the time of installation, street trees shall be a minimum 2-inch caliper measured six inches (6”) above the ground and shall be installed as shown in City of Sedro-Woolley standard detail 3-31 (ANSI Standards) and the City of Sedro-Woolley Urban Forestry Manual, July 2003.

Street trees shall not be planted closer than ten feet (10’) from driveways/alleys, and thirty feet (30’) from intersections.

On roadways with speeds greater than thirty-five miles per hour (35 mph), street trees shall be located beyond the “Clear Zone” as defined in the WSDOT Design Manual.

3.6 ILLUMINATION

3.6.1 General

All new commercial or residential subdivisions, short plats or property development shall provide streetlights in accordance with the standards for such improvements of the City, and they will be owned and operated by the City or its designee (Puget Sound Energy). Non-standard, internal, privately owned and maintained streetlights may be acceptable as permitted by the Public Works and Planning Departments.

3.6.2 Design Standards

A public street lighting plan submitted by the applicant and approved by **Intolight** lighting services from Puget Sound Energy (PSE) and the Public Works Director / City Engineer will be required for all streetlight installations. Installations on privately owned property shall be designed to the same (IES) standards, except that ownership and maintenance is by private party or homeowners’ association. Type of installation will be as directed by the City except where noted herein.

Refer to the City of Sedro-Woolley Streetlight Installation Guidelines for specific equipment and installation guidelines and procedures. Electrical service for streetlights shall not be metered, unless private or directed by the Public Works Director / City Engineer.

Design of illumination for all roadways shall be in accordance with the most current version of the WSDOT Traffic Manual M 51, the most current version of the WSDOT Design Manual, M-22, Chapter 710, and all other City standards for illumination included within or referenced by these standards.

Intolight or an engineering firm approved by the City capable of performing such work will prepare all public streetlight designs, and those to be used by the public. The engineer will be licensed by the State of Washington. After the system is approved, completed, and accepted, a set of “as-built” mylars and electronic submittals will be submitted to the City as a permanent record.

Streetlights will be located in accordance with the City of Sedro-Woolley Street Light Standards (see Appendix). In addition, intersections will be illuminated to 1.5 times the highest footcandle requirement of the streets surrounding the intersection, if none of the intersecting streets average maintained horizontal illumination level (footcandles) is equal to or greater than one footcandle.

Exception: In residential zones, local streets intersecting local or minor collector streets do not need 1.5 times the illumination at intersections, provided a luminaire is placed at the intersection. Streetlight layout will be first considered for one-sided street placement then opposite-side street placement. Staggered spacing is preferred.

On low volume CBD streets, pedestrian lighting is required using ornamental lampposts. Standard cobra-head type streetlights are required as necessary to maintain the required average footcandle and uniformity ratio. All other street classifications require the use of standard cobra-head type streetlights. Specifications for each type of streetlight pole and spacing are included in the Appendix.

Line loss calculations shall show that no more than five percent (5%) voltage drop occurs in any circuit. Branch circuits will serve a minimum of four (4) luminaires.

Poles shall be located outside of the clear zone as defined by WSDOT.

Pole foundations will be per Standard Plan 3-39. The City will approve the poles.

Junction boxes (J-boxes) will be placed as shown in Standards Plan 3-40.

3.6.3 Staking

All surveying and staking shall be performed by an engineering or surveying firm capable of performing such work. The engineer or surveyor directing such work shall be licensed by the State of Washington.

At the Pre-construction Meeting, the City will discuss staking requirements. The City may inspect construction staking prior to construction.

The minimum staking of luminaires will be as follows:

- A. Location and elevation to the center of every pole base.
- B. Location and elevation of each service disconnect.
- C. Location and elevation of each J-Box.
- D. Location of conduit crossings.

3.6.4 Testing

All luminaires will be subject to an electrical inspection. Lamp, photocell, and fixture to be owned by the City shall be warranted for a period of one (1) year.

3.7 SIGNALS

3.7.1 General

Signals will be installed per the requirements set forth herein. This work shall consist of furnishing and installing a complete and functional traffic control system of controllers, signals, interconnect conduit, and appurtenances as required by the City.

3.7.2 Design Standards

Signal systems will be designed in accordance with the specifications as set forth in City, Skagit County, WSDOT Design Manual, and the WSDOT/APWA Standard Specifications.

An engineering firm capable of performing such work shall prepare all public signal designs. The engineer shall be licensed by the State of Washington. All applicable requirements set forth in Section 2.1.4 shall be included. Approval of plans and specifications shall be obtained before construction commences.

Signal or strain pole foundations shall be per Standard Plan J-7a.

3.7.3 Induction Loops

Induction loops shall be constructed per WSDOT/APWA Standard Specification 8-20.3(14)C, WSDOT Standard Plan J-8a, Standard Plan 3-44, and the following:

- A. Loops shall not be cut into final lift of new asphalt.
- B. Loops shall be cut in existing asphalt or leveling course to sub-base before intersection is overlaid.

3.7.4 Staking

All surveying and staking shall be performed by an engineering or surveying firm capable of performing such work. The engineer or surveyor directing such work shall be licensed by the State of Washington. Staking shall be maintained throughout construction.

At the Pre-construction Meeting, the City will discuss staking requirements. The City may inspect construction staking prior to construction.

The minimum staking of signals shall be as follows:

- A. Location with cut or fills to center of all pole bases.
- B. Location of junction boxes.
- C. Location of all corners of controller base.

- D. Location of service disconnects.
- E. Locations of conduit crossings.

3.7.5 Testing

All signals shall be subject to any necessary electrical inspections as well as requirements as set forth in the WSDOT Design Manual and the WSDOT/APWA Standard Specifications.

A signal system will not be approved or accepted by the City until the signal has performed correctly to the City's satisfaction for a thirty (30) day "check-out" period as outlined below.

Controller and cabinet testing by WSDOT is required. All specifications and material samples shall be submitted to the City for review and approval prior to installation.

3.7.6 Check-Out Procedure

The contractor shall call for an intersection checkout after completing the controller cabinet installation along with all other signal equipment complete with wiring connections. All parts and workmanship shall be warranted for two (2) years from the date of acceptance.

New signals shall operate without any type of failure for a period of thirty (30) days. The contractor shall have technical personnel available to respond to system failure within twenty-four (24) hours during the thirty (30) day "check-out" period.

Failure of any control equipment or hardware within the "check-out" period will restart the thirty (30) day "check-out" period.

3.8 ROADSIDE FEATURES

3.8.1 General

Miscellaneous features included herein shall be developed and constructed to encourage the uniform development and use of roadside features wherever possible.

3.8.2 Design Standards

The design and placement of roadside features included herein shall adhere to the specific requirements as listed for each feature, and, when applicable, to the appropriate standards as set forth in Section 2.1.1.

3.8.3 Staking

All surveying and staking shall be performed by an engineering or surveying firm capable of performing such work. The engineer or surveyor directing such work shall be licensed by the State of Washington. Staking shall be maintained throughout construction.

At the Pre-construction Meeting, the City will discuss staking requirements. The City may inspect construction staking prior to construction.

3.8.4 Testing

Testing shall be conducted at the developer or contractor's expense on all materials and construction as specified in the WSDOT/APWA Standard Specifications and with a frequency as specified in the WSDOT Construction Manual.

3.8.5 Survey Monuments

- A. All existing survey control monuments that are disturbed, lost, or destroyed during surveying or construction shall be replaced with the proper monument as outlined in B or C below by a land surveyor registered in the State of Washington at the expense of the responsible builder or developer.
- B. A cast-in-place concrete surface monument per Standard Details 3-36 & 3-37 (WSDOT Standard Plans H-6 and H-7, with the exception that the letters W-S-D-O-T are not necessary) except that the Monument Case and Cover are not necessary outside of right-of-way unless subject to traffic loads, but shall be replaced with a white guard post, shall be placed as outlined below.

C. Required Monument Locations

Appropriate monuments will be placed:

- 1. At all street intersections;
 - 2. At the PC and PT's of all horizontal curves;
 - 3. At PI of all horizontal curves of streets where the PI lies within the limits of the traveled roadway;
 - 4. At all section corners, quarter corners, and sixteenth corners;
 - 5. At all corners, control points, and angle points around the perimeter of subdivisions as required by the City. 1/2" diameter (#4) or 3/4" diameter (#6) reinforcing bar or 3/4" diameter galvanized pipe is acceptable at these locations, provided they do not coincide with points of more significant monumentation.
- D. The monument case shall be installed after the final course of surfacing has been placed.

3.8.6 Bus Shelter and Amenities

- A. Bus zone requirements shall be coordinated by the applicant and shall accommodate the recommendations of the Skagit Area Transit (SKAT). These requirements may include, but are not limited to, providing district access to the site for mass transit areas, providing for bus shelters, and providing an on-site transit information area.

The applicant shall provide documentation to the City that the mass transit recommendations have been accommodated. (Contact the appropriate transit authority for standard plan details.)

- B. The Sedro-Woolley School District shall use the following criteria in placement and design of school bus stops:
 - 1. A school bus stop is required for each new residential subdivision or apartment complex where school children are to be boarding or deboarding unless it is determined by the Sedro-Woolley Way School District that a new bus stop is not required because adjacent facilities already exist for the site.
 - 2. The Sedro-Woolley School District and the City will determine placement.
 - 3. Location of school bus stops will be designed with safety as a paramount concern. Major arterials with high traffic counts should be avoided where possible, and only used when bus pullouts are available and significant protection provided for children.
 - 4. Location of school bus stops will be designed to compliment the residential environment and provide convenient location and access for neighborhood children, including sidewalk access.
 - 5. Every effort shall be made to make school bus stops and sidewalk access to school bus stops a safe and friendly pedestrian environment.
 - 6. SKAT and the Sedro-Woolley School District should make every effort to coordinate the location of bus stops.
- C. The physical location of any bus stop will be primarily determined by the following considerations: maximizing safety, operational efficiency, and minimizing impacts to adjacent property. Bus pullouts may be required on all arterial roads for safe bus berthing and to minimize impacts on traffic flow of buses stopping. Maintaining adequate separation between driveways/intersections and bus pullouts can increase the safety and efficiency of both the roadway and the transit service.
- D. All Skagit Area Transit (SKAT) and Sedro-Woolley School District bus stops shall be identified in some fashion. This may include pavement marking and bus stop signs. Contact SKAT for details on SKAT Transit sites.
- E. Passenger shelters may be required at bus pullouts, and transfer centers. Shelters may also be required at bus stops as determined by SKAT and the City.
 - 1. The transit authority will maintain the transit shelters. School bus stop shelters shall be maintained by the subdivision, Homeowner's Association, or apartment owner, whichever is appropriate.
 - 2. Shelter size shall be appropriate to anticipated service and use. The

applicable transit agency and the City will determine the size of transit shelters. School bus shelters shall provide a minimum of fifty square feet (50 sq.ft.) of shelter for each twenty-five (25) lots in a subdivision, or each twenty-five (25) units of two (2) or more bedrooms in an apartment complex.

3.8.7 Mailboxes

- A. During construction, existing mailboxes shall be accessible for the delivery of mail, or if necessary, moved to a temporary location. Temporary relocation shall be coordinated with the U.S. Postal Service. The mailboxes shall be reinstalled at the original location, or if construction has made it impossible, to a location as outlined below and approved by the U.S. Postal Service.
- B. Location
 - 1. Bottom or base of box height shall be as required by the Postmaster.
 - 2. Front of mailbox shall be eighteen inches (18") behind vertical curb face or outside edge of shoulder, with a minimum six feet (6') of sidewalk behind the mailbox. See Standard Detail 3-34.
 - 3. New developments. Clustered mailboxes are required. Contact the U.S. Postal Service for details. See Standard Detail 3-34.
 - 4. All construction plans that involve location / relocation of mailboxes shall show such locations in the plans, and have a signature block for the postmaster's approval.
- C. Mailboxes shall be set on posts strong enough to give firm support, but not to exceed 4 x 4-inch wood or material and design with comparable breakaway characteristics.

3.8.8 Guardrails

For purposes of design and location, all guardrails along roadways shall conform to the criteria of the "WSDOT Design Manual" as may be amended or revised.

3.8.9 Rock Walls (Rockeries)

- A. Rock walls may be used for erosion protection of cut or fill embankments up to a maximum height of eight feet (8') in stable soil conditions that will result in no significant foundation settlement or outward thrust upon the walls. For height over four feet (4') or when soil is unstable, a structural wall of acceptable design stamped by a licensed structural engineer shall be used. Rock walls over four feet (4') high will be subject to inspection by a geotechnical engineer as outlined in the following paragraph.

Any rock wall over 48 inches (4') high in a fill section requires an engineered design by a geotechnical engineer. The geotechnical engineer shall continuously inspect the installation of the wall as it progresses and shall submit inspection reports, including compaction test results and photographs taken during the construction, documenting the techniques used and the degree of conformance to the geotechnical engineer's design.

In the absence of such a rock wall design, walls having heights over four feet (4'), or walls to be constructed in conditions when soil is unstable, require a structural wall having a design approved by the Public Works Department or the Planning Department if outside of the right-of-way. The design of structural walls shall be by a professional structural engineer qualified in retaining wall design. Structural walls require issuance of a Building Permit prior to construction.

Rock walls over three feet (3') tall and subject to pedestrian access shall be protected by a fence or handrail per Standard Plan 3-29.

- B. The rock material shall be as nearly rectangular as possible. No stone shall be used that does not extend through the wall. The rock material shall be hard, sound, durable, and free from weathered portions, seams, cracks, and other defects. The rock density shall be a minimum of one-hundred sixty pounds per cubic feet (160 pcf).
- C. The rock wall shall be started by excavating a trench having a depth below subgrade of one half the base course or one-foot (1') (whichever is greater).
- D. Rock selection and placement shall be such that there will be minimum voids, and in the exposed face, no open voids over six inches (6") across in any direction. The final course shall have a continuous appearance and shall be placed to minimize erosion of the backfill material. The larger rocks shall be placed at the base of the rockery so that the wall will be stable and have a stable appearance. The rocks shall be placed in a manner such that the longitudinal axis of the rock will be at right angles or perpendicular to the rockery face. The rocks shall have all inclining faces sloping to the back of the rockery. Each course of rocks shall be seated as tightly and evenly as possible on the source beneath. After setting each course of rock, all voids between the rocks shall be chinked on the back with quarry rock to eliminate any void sufficient to pass a two-inch (2") square probe.
- E. The wall backfill shall consist of 1½-inch washed rock or as specified by a licensed engineer. This material shall be placed to an eight-inch (8") minimum thickness between the entire wall and the cut or fill material. The backfill material shall be placed in lifts to an elevation approximately six inches (6") below the top of each course of rocks as they are placed, until the uppermost course is placed. Any backfill material on the bearing surface of one rock course shall be removed before setting the next course.
- F. Drain rock, perforated drainage pipe, and filter fabric shall be installed at the base of the wall as per Drawing No. 3-22. The City Engineer, upon a showing by the developer that no subsurface water problem exists, may waive this pipe requirement.

3.8.10 Parking Lots

Storm water detention / retention shall be provided, and shall follow the criteria as set forth in Chapter 4 of these standards.

Plans and specifications are required by the Public Works Department and shall be submitted for review and approval by the City with respect to storm drainage discharge and on site retention or detention, matching street and/or sidewalk grades, access locations, parking layout, and to check for future street improvement conformity and City zoning regulations.

Parking lot surfacing materials shall satisfy the requirement for a permanent all-weather surface. Asphalt concrete pavement and Portland Cement Concrete pavement satisfy this requirement and are approved materials. Generally, gravel surfaces are not acceptable or approved surface material types. Low-impact design elements such as porous pavements are encouraged for parking areas. Combination grass/paving systems are approved surface material types, however, their use requires submittal of an overall parking lot paving plan showing the limits of the grass/paving systems and a description of how the systems will be irrigated and maintained. If the City determines the grass/paving system is not appropriate for the specific application, alternate approved surfacing materials shall be utilized.

The City will determine minimum requirements for parking lot capacity.

Parking shall be laid out in accordance with section 3.9 of these standards.

Parking lots, including fire lanes, shall be marked in accordance with section 3.2.4 of these standards.

3.8.11 Transportation Impact Study and Mitigation

A Transportation Impact Study (TIS) may be required whenever a project generates more than ten trips during any peak hours. A “trip” is defined as one vehicle movement either entering or exiting the subject site.

As outlined in the SWMC, in addition to frontage improvements, the City may require off-site right-of-way improvements, either abutting or not abutting the subject property. These may include traffic signals, channelization, road widening, turn lanes, or other improvements, the need for which is directly attributable to development of the subject property. At the discretion of the Public Works Director / City Engineer, pro-rata share contributions may, in some cases, be submitted for installation of the improvements.

The Transportation Impact Study shall be prepared under the direction of a registered Civil Engineer with experience in traffic engineering, in conjunction with the Sedro-Woolley Traffic Impact Study Guidelines. Final documents shall bear the seal of the responsible engineer.

3.8.12 Roadside Obstacles

Non-yielding or non-breakaway structures which may be potential hazards to the traveling public, shall be placed with due regard to safety. On urban roads with a vertical curb section, hazardous objects shall be placed at the back of the sidewalk, and as close to the right-of-way line as practical. Such an object shall not be placed in a sidewalk.

On urban roads with a speed limit of forty miles per hour (40 mph) or greater, poles and obstacles shall be placed in accordance with Drawing No. 3-13, or at the back of the sidewalk, whichever is greater.

3.9 PARKING

3.8.1 General

Parking shall conform to this section.

Standard 90 degree parking stall dimensions shall be nine feet (9') wide by nineteen feet (19') long. 90 degree compact parking stalls shall be a minimum of eight feet (8') wide by sixteen feet (16') long. Compact parking stalls shall be labeled "COMPACT."

Isle widths for 90 degree parking shall be a minimum twenty five feet (25').

Bump stops or curbing shall be provided if overlapping sidewalk or against a wall. Minimum two feet (2') of overhang shall be provided past a curb or bump stop. If no bump stop is provided, and vehicles will overhang the sidewalk or other pedestrian walkway, a minimum of 5' width shall be provided on the sidewalk or pedestrian walkway.

If head to head parking is to be used, a minimum of five feet (5') front face to front face of the bump stops or curbing shall be provided.

ADA handicap accessible parking shall have dimensions and markings which conform to WSDOT Standard Plan M-17.10-00.

ADA slope requirements: No slope shall be greater than 2.0% in any direction, including the arithmetic mean (vector sum) of the longitudinal and transverse slopes.

CBD Parking:

- a. 80-foot right-of-way:
 - i. 56 feet face-of -curb to face-of-curb width
 - ii. 11.5 feet sidewalks + 6-inch vertical curb
 - iii. 55 degree parking
 - iv. 13-foot stall depth
 - v. 10-foot stall width
 - vi. Two 15-foot driving lanes
 - vii. First and last stalls on each side of street shall be ADA accessible stalls. (4 ADA stalls per block)
 - viii. No parking stall shall begin or end within 25 feet of the curb return at an intersection or shall begin or end within 10 feet of an alley.

- b. 66-foot right-of-way - parking shall be laid out as 55 degree parking as shown above for 80-foot right-of-way on one side only, or shall have parallel parking on one side only to match existing sections or at the Director's discretion. Curb-to-curb width is 42 feet.

C.

PARKING LOT MODULE LAYOUT

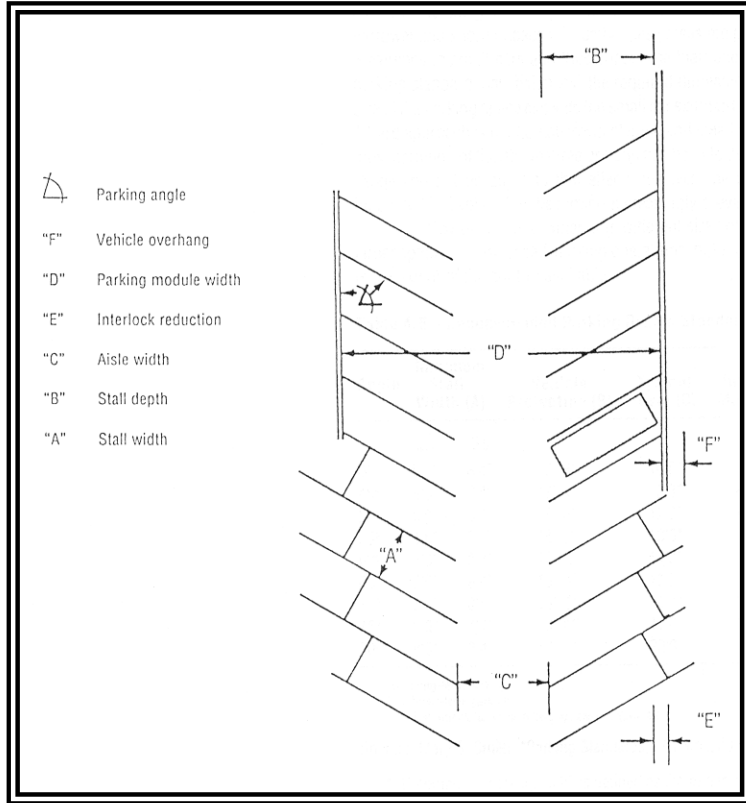

Angle	Min. Stall Width (A)	Vehicle Projection (B)	Typical Aisle (C)	Interlock Module (D)	Reduction (E)	Overhang (F)
< 0°	9'	8'	12'	28'	-	3'
45°	9'	18.5'	14'	51'	2'	2'
50°	9'	19'	15'	53'	2'	2'
55°	9'	19.5'	15'	54'	2'	2.5'
	(10' CBD)	(13' CBD)	(30' CBD)	(56' CBD)	(N/A CBD)	(N/A CBD)
60°	9'	20'	16'	56'	1.5'	2.5'
65°	9'	20'	17'	57'	1.5'	2.5'
70°	9'	20'	18'	58'	1'	2.5'
75°	9'	20'	23'	63'	1'	2.5'
90°	9'	19'	25'	63	-	3'