

PLAN COVER

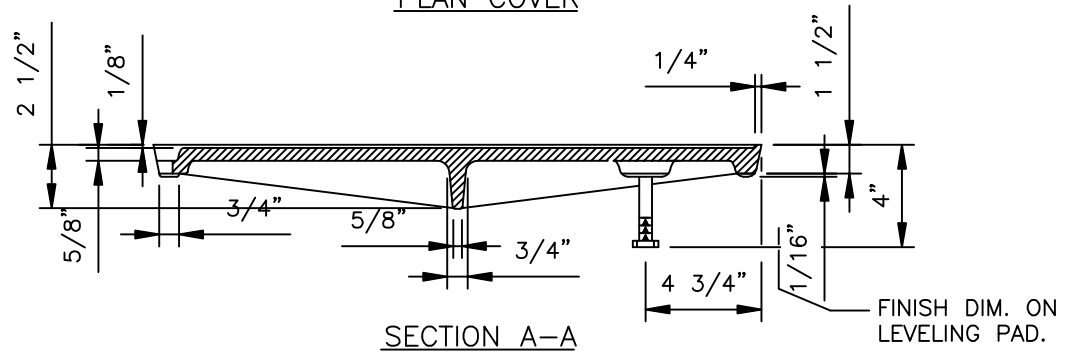

SECTION A-A

NOTES:

1. USE WITH FRAME DRILLED AND TAPPED FOR LOCKING BOLTS.
2. USE WITH TWO LOCKING BOLTS 5/8"-11 NC STAINLESS STEEL TYPE 304 STEEL SOCKET HEAD (ALLEN HEAD) CAP SCREWS, 2" LONG.
3. MATERIAL IS CAST IRON PER ASTM A48 CLASS 30.



PUBLIC WORKS
DEPARTMENT

SOLID COVER

DWG.
NO. 4-7