

PLAN

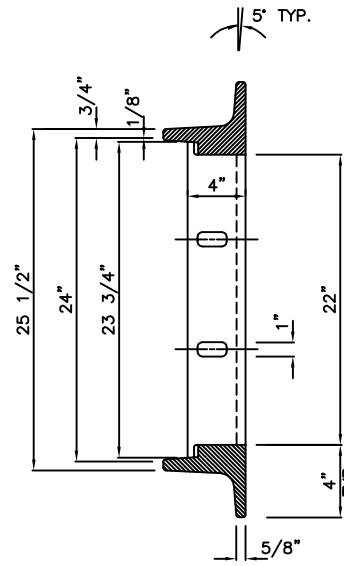

SECTION B-B

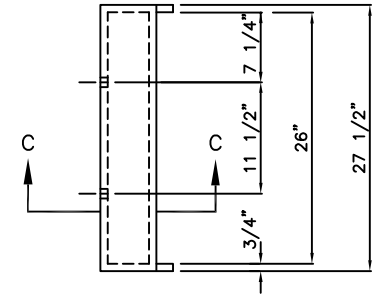

HOOD DETAIL

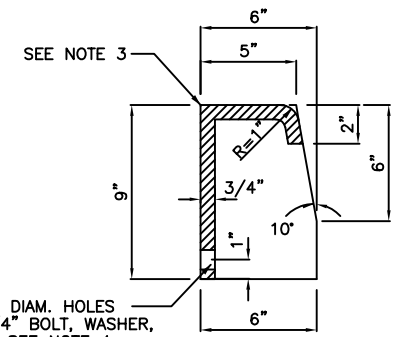

SECTION C-C

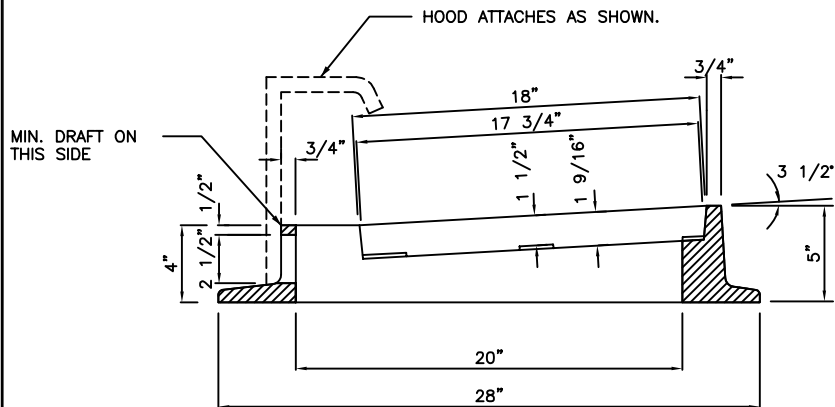

SECTION A-A

NOTES:

1. MATERIAL IS CAST IRON ASTM A48 CLASS 30.
2. SEE DWG. NO. 4-10 FOR VANED GRATE.
3. PATTERN ON TOP SURFACE OF HOOD SHALL BE 3/16" NON-SKID DIAMOND.
4. BOLT, WASHER, AND NUT SHALL BE GALV. OR CORROSION RESISTANT.



PUBLIC WORKS DEPARTMENT

THRU CURB INLET

DWG. NO. 4-8