

SECTION A-A

SECTION B-B

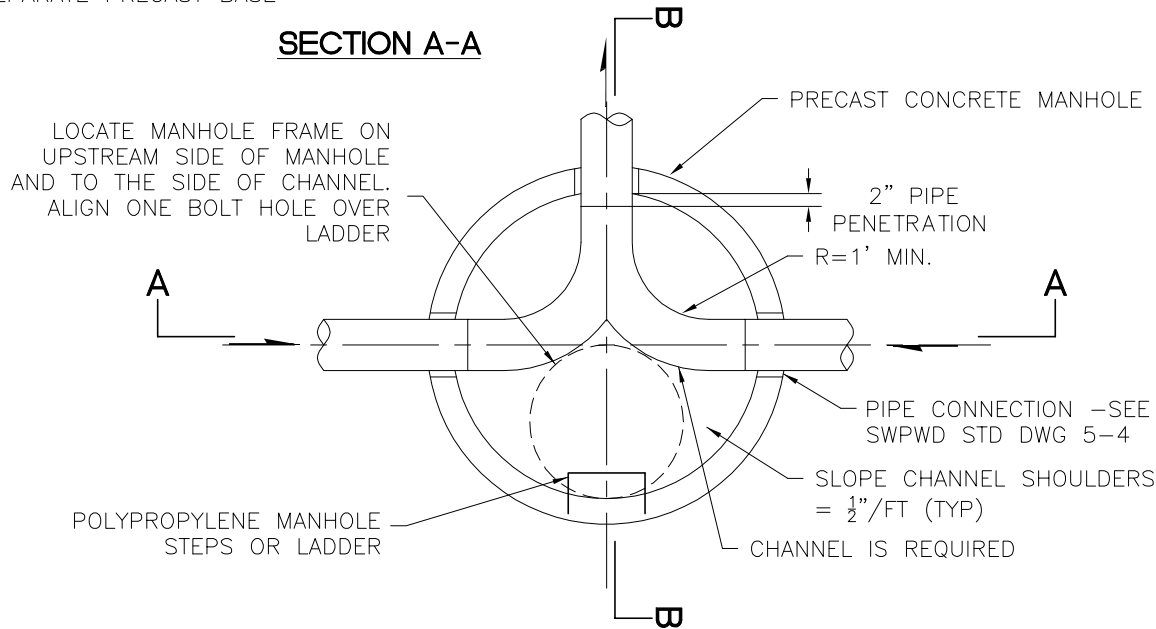

NOTES:

1. SHALLOW MANHOLES SHALL ONLY BE USED WITH SPECIAL WRITTEN APPROVAL FROM THE ENGINEER
2. PRECAST MANHOLE SECTION AND FLAT SLAB COVER SHALL CONFORM TO WSDOT STANDARD PLANS, CURRENT EDITION.
3. ALL MANHOLE JOINTS SHALL BE GROUTED TO INSURE A WATER TIGHT SEAL AND THE INTERIOR SHALL BE TROWLED TO A BROOM FINISH.
4. ALL CHANNELS IN THE MANHOLE BASES SHALL BE COVERED BY A RIGID MATERIAL DURING CONSTRUCTION OF THE ROAD SURFACES TO PREVENT FOREIGN MATERIALS FROM ENTERING SYSTEM.
5. WHEN CONSTRUCTING MANHOLE OVER AN EXISTING MAIN, SUPPORT PIPE(S) AND MANHOLE SECTION WITH CONCRETE BLOCK AND POUR BASE AS SHOWN. REMOVE TOP HALF OF MAIN PIPE AND FORM SIDE CHANNEL(S) AS REQUIRED.



PUBLIC WORKS
DEPARTMENT

SHALLOW SANITARY SEWER MANHOLE DETAIL

DWG.
NO. 5-5